

PELLETS

BioWIN LITE

THE SIMPLE AND
CONVENIENT SOLUTION

windhager

from £ 4,990

HOPPER OPTIONS OF 107KG OR 200KG -
UP TO 14 DAYS OPERATING TIME

INFOWIN OPERATING MODULE -
STATUS AND CLEANING INFORMATION

ONLY 1,5 M² SPACE REQUIREMENTS

FULLY AUTOMATIC CLEANING FUNCTION



Wood Pellet Boiler
Rated output: 10, 15, 21, 26 kW

BioWIN LITE

PROVIDING QUALITY AND EFFICIENCY IN A LITE FORMAT



- Hand feed appliance
- Modulating output
- Quiet operation
- Long life ignition
- System control options
- Comprehensive UK Support and Customer Service

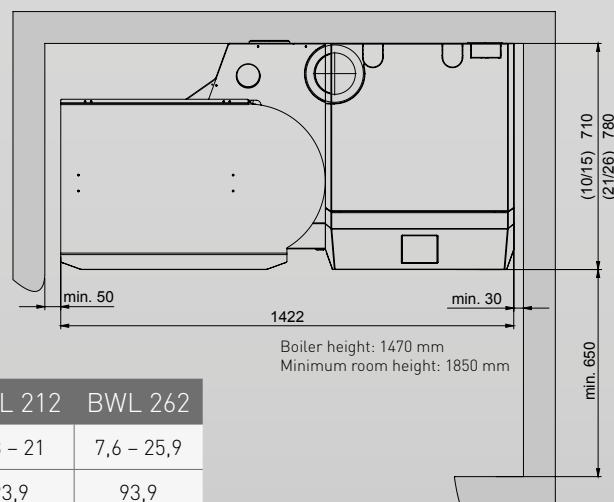
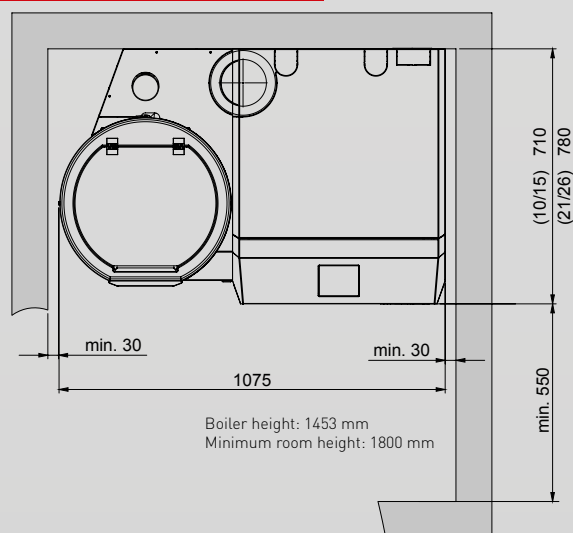

BioWIN lite		BWL 102	BWL 152	BWL 212	BWL 262
Rated thermal output range	kW	3,0 – 9,9	4,3 – 15	6,3 – 21	7,6 – 25,9
Boiler efficiency at nominal load	%	94,4	93,8	93,9	93,9
Pellet hopper capacity options	kg	107 / 200			
Total weight	kg	247 / 300		269 / 322	
Weight of boiler body	kg	186		207	
Minimum weight of main boiler body	kg	156		177	
Flue gas connection diameter	mm	130			
Power consumption part load / nominal load	W	16 / 28	18 / 33	19,6 / 41,2	21 / 48

Windhager Installer