

Wood gasification boiler ORLIGNO 200



ISO 9001  CE ISO 14001

Compliant with EN 303 - 5 norm



Wood as fuel

Wood is a renewable fuel, just like the sun, tidal energy or the wind. These are energy sources which cannot be exhausted. Unlike other energy sources, wood is a fuel which can be accumulated and stored without any energy loss. Storing lowers the humidity of the wood whilst simultaneously raising its fuel value (the amount of energy which can be used during combustion). Wood is also the only fuel whose carbon dioxide (CO₂) balance is zero, meaning that while vegetating through photosynthesis process it absorbs the same amount of carbon dioxide as it emits while combusting.

Chemical contents of wood with 15% humidity

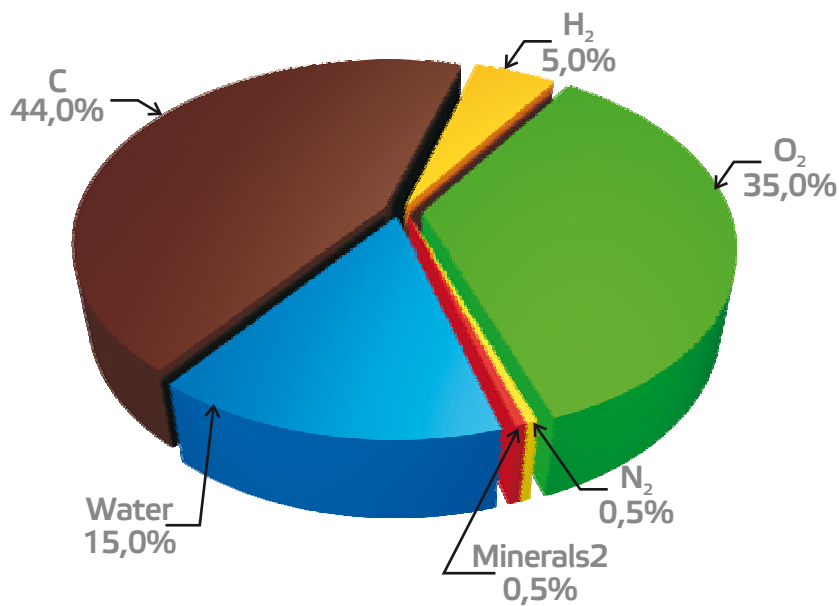

CO₂ circulation graph

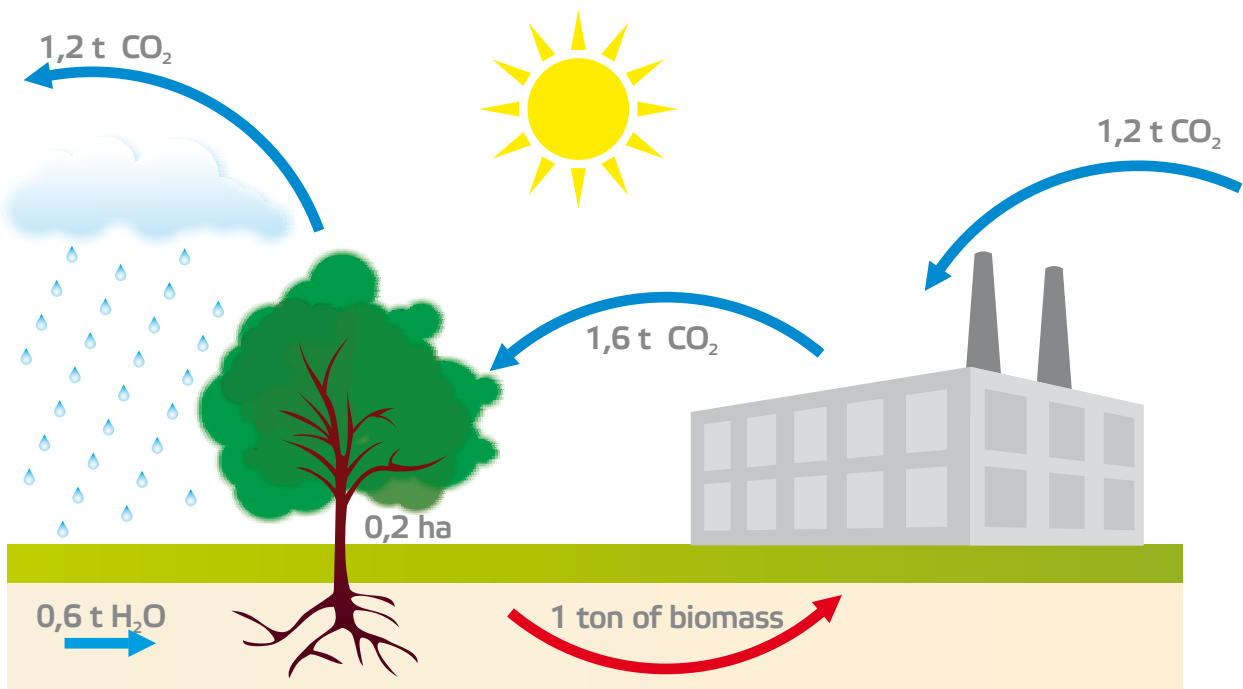

5-year warranty for boiler tightness

Wood gasification as an economic source of heating

Wood gasification is a thermal decomposition of wood with a significant air (oxygen) deficit which results in the creation of combustible gases (wood gases) and ash.

Modern wood gasification boilers use the energy from the wood three times more effectively than appliances with a traditional hearth and their emissions are similar to gas boilers.

Wood gasification process in central heating boilers can be divided into four main phases:

1. Drying and de-gassing wood at a temperature of 450°C.
2. Combustion of the mixture of wood gas and secondary air at a temperature of 560°C
3. Burning up the flame and heat emission at a temperature of 1200°C
4. Fumes of a temperature of 160°C are emitted through the chimney flue.

PHASE FOUR

Fumes of a temperature of 160°C are emitted through the chimney flue

PHASE ONE

Drying and de-gassing wood at a temperature of 450°C

PHASE TWO

Combustion of the mixture of wood gas and secondary air at a temperature of 560°C

PHASE THREE

Burning up the flame and heat emission at a temperature of 1200°C

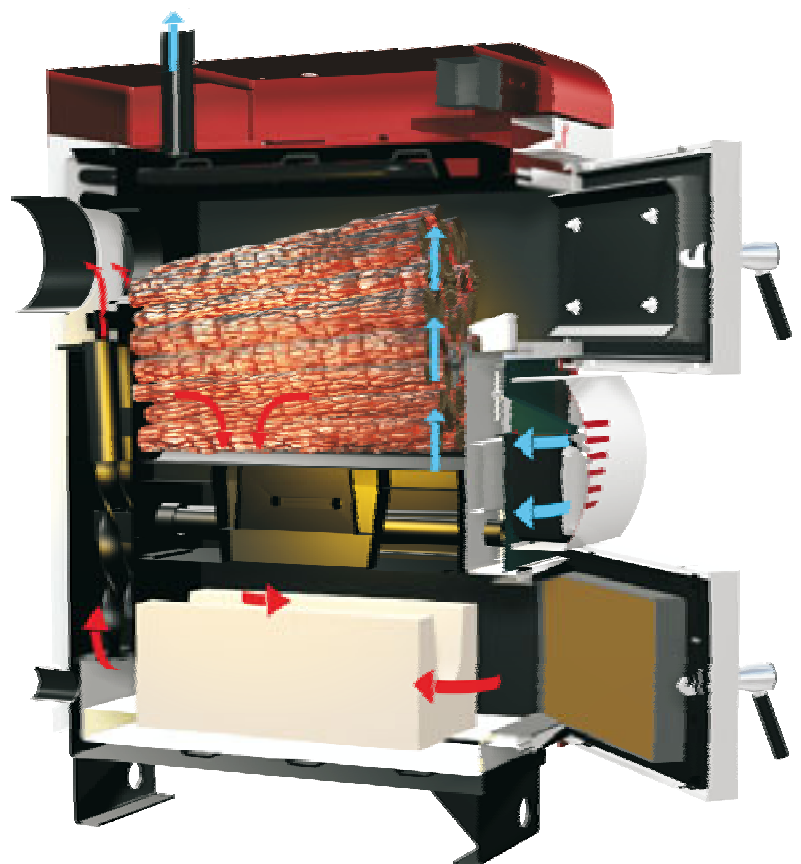

5-year warranty for boiler tightness

Wood as fuel for wood gasification boilers

During the proper wood combustion (gasification process) the exhaust gases and ash created do not contain substances which are harmful to the natural environment, moreover the amount of created ash constitutes 1% of inputted material.

Humidity of the wood is a very important factor in the process of combusting it. The less water the wood contains, the higher its fuel value. In case of wood with 20% humidity, about 30-40% of the general amount of wood needed for one heating season can be saved.

It is recommended to cut the trees down during winter period when the sap no longer circulates within them. After felling, the wood needs to be cut into logs about 35-45 cm long and divided into halves or quarters as soon as possible. The suitably prepared wood should be stored for the period of 18-24 months in a ventilated room and fairly sheltered place. Oak is an exception as due to its high density and the content of tannin it requires storing outside and exposure to rain for 12 months, and then needs drying under cover for 2-3 years. After 2 years tannin, volatile ingredients of resin, turpentine, etc will be removed from the wood and the humidity will reach 15-20%. It is the correct level of wood drying.

Recommended fuel for wood gasification boilers is hard wood, meaning hornbeam, beech, oak, birch with 20% maximum humidity. The wood from conifers, despite having a higher fuel value in general, is not as profitable as the wood from deciduous trees considering the density. The wood derived from conifers is undoubtedly more calorific as it is very resinous but it combusts too quickly giving away little glow. The resin contaminates the loading chamber which is why it should be used mainly in the initial stage of ignition.

Wood humidity

The state of the wood	Humidity	Fuel value
After felling	50-60%	2,0 kWh/kg = 7,2 MJ/kg
After a year of seasoning	25-35%	3,4 kWh/kg = 12,2 MJ/kg
Stored for a few years	15-25%	4,0 kWh/kg = 14,4 MJ/kg

Comparison of fuels regarding their fuel value

Fuel	Fuel value (MJ/kg)
Light fuel oil	42,0
Earth gas GZ-50	37,0
Coal	31,0
Coke	28,5
Brown coal	15,0
Dry wood	15,0

Comparison of some types of trees regarding their density

Type of tree	Humidity	Fuel value
C o n i f e r o u s		
Pine	700	480
Larch	760	600
Spruce	740	430
Fir	1000	450
D e c i d u o u s		
Oak	1080	710
Elm	950	680
Ash	920	750
Beech	990	730
Hornbeam	1080	830
Alder	690	530
Birch	650	650

Clean solution - ORLIGNO 200

ORLIGNO 200 boilers create a new pathway in wood gasification boilers technology. Unique design as well as a range of constructional solutions benefits the comfort of use and customer satisfaction. Technical parameters resulting from wood combustion process meet the most rigorous European norms and provide nearly twice as much heat as traditional boilers or fireplaces. The appliances can work in open as well as pressurized systems in accordance with current regulations.

ORLIGNO 200 boilers are designed to heat a variety of places. They are most commonly used in detached houses, drying rooms, production halls and workshops. Available types are as follows: 18 kW, 25 kW, 40 kW, 60 kW, 80 kW.

The ORLIGNO 200 boiler can combust wood of various granulation from sawdust to blocks. Shavings and other small pieces should be burnt together with blocks.



ORLIGNO 200 technical data

Boiler type	Measured in	18 kW	25 kW	40 kW	60 kW	80 kW
Power range	kW	7÷18	10÷25	16÷40	24÷60	32÷80
Efficiency	%	91	91	91	91	91
Weight*	kg	525	525	595	975	1165
Loading chamber (gasification) capacity	dm ³	85	120	185	310	465
Burning period	hrs	Up to 12				
Chimney flue diameter	mm	180	200	200	210	210
Length of wooden blocks	cm	50	50	50	75	100
Recommended wood humidity	%	15÷25				

ORLIGNO 200 size

Boiler type	Measured in	18 kW	25 kW	40 kW	60 kW	80 kW
Height	A - mm	1300	1300	1555	1570	1570
Width	B - mm	720	720	1100	860	860
Depth	C - mm	1100	1100	1085	1360	1640



Choosing the right boiler for the surface:

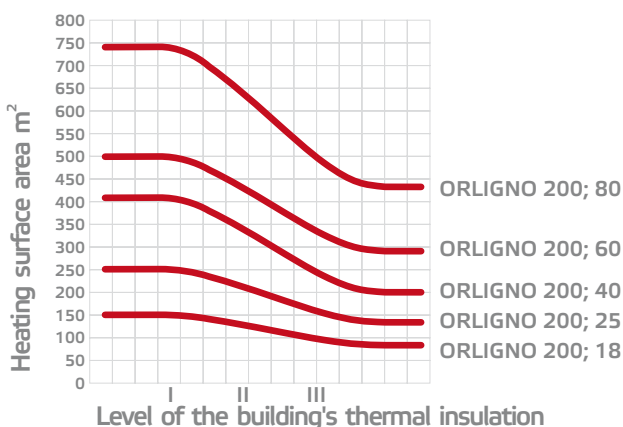

How do I know which boiler is suitable for me:

- An installation designer will estimate how much heat will be needed in the building.
- The result needs to be increased by 20% (so called boiler over-sizing).
- You can use the graph enclosed.

Caution !

The graph is for information only and ORLANSKI cannot be held liable if a boiler with unsuitable power output is selected.

5-year warranty for boiler tightness

Clean solution - ORLIGNO 200

Boiler advantages

- ❑ Efficiency 91%
- ❑ 5-year warranty for boiler tightness
- ❑ Low cost maintenance
- ❑ User-friendly
- ❑ Small amount of ash residue
- ❑ Large loading capacity
- ❑ Length of wooden blocks 50 cm (18, 25, 40 kW), 75 cm (60 kW), 100 cm (80 kW)
- ❑ Up to 12 hours continuous operation
- ❑ Types available 18-80 kW
- ❑ Electronic regulator with an option to fit remote control system
- ❑ Made of the best quality 8 mm boiler steel
- ❑ Environmentally friendly; boiler in the 3rd emission class according to PN-303-5
- ❑ Suitable to operate in a pressurized systems



5-year warranty for boiler tightness

The best materials, the best quality

- ORLIGNO 200

Boiler body - the boiler's inner coat is made of 8mm thick sheet metal elements which have been welded together. The outer coat is made of 4 mm thick constructional steel sheet metal. Ports are made of steel pipes.

Heat exchanger - blazers are made of 4 mm thick boiler pipe whose diameter is 57 mm.

Insulation and outer casing - 20 mm thick insulation materials are protected with 0.8 mm thick steel sheet metal varnished in a powder way.

Burner nozzle - ceramic element is made of heat resistant material whose operating temperature is 1350°C.

Chimney flap - made of high quality constructional sheet metal.

Fan - situated at the front of the boiler, fitted with 50W electric engine.

Boiler controller - llocated under the upper panel cover; enables the stable operation of the appliance.

Chimney flue - made of 4mm thick steel pipe.

Ashtray - the combustion chamber steel bottom is fitted with ceramic moulder (operating temperature 1800°C) and additionally laid with a layer of glow-concrete which ensures protection from a high temperature.

Boiler door - made of high quality constructional steel, insulated with an insulating material and filled with glow-concrete from the inside (lower door). A fibreglass rope covered with a layer of silicone ensures the door hermeticity (upper door).

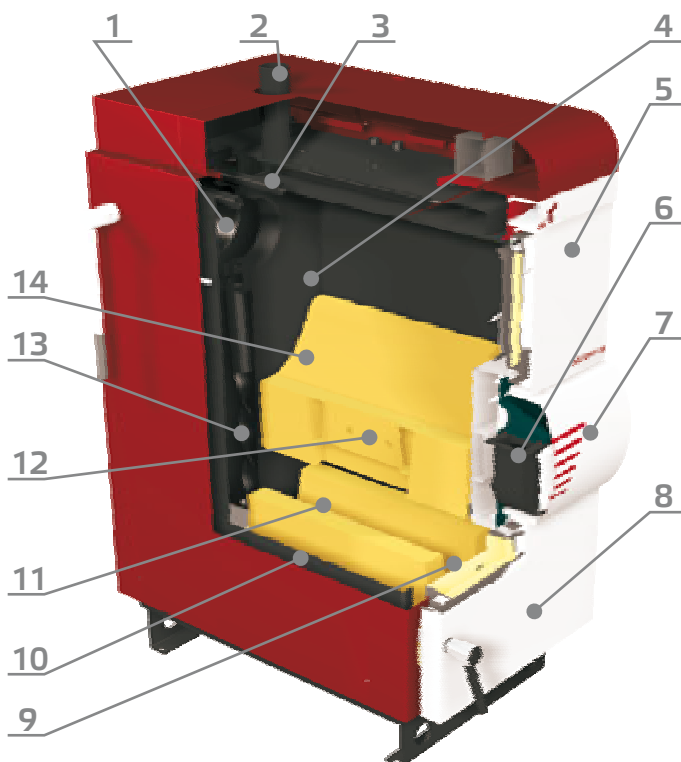

1. Chimney flap
2. Heating water exit
3. Cooling coil
4. Loading (gasification) chamber
5. Upper door
6. Fan
7. Fan cover
8. Lower door
9. Ashtray
10. Boiler insulation
11. Combustion chamber
12. Ceramic nozzle
13. Secondary air flow
14. Ceramic moulders

5-year warranty for boiler tightness

Total control - ORLIGNO 200

Microprocessor temperature regulator Ekoster 2 is designed to control the heating process and the activation of circulation pump in the central heating installation.

The regulator fulfils the following tasks:

- ❑ Upholding the pre-set boiler temperature through heating control
- ❑ Smooth start of the fan which eliminates wood gas detonations
- ❑ Adjustable fan power (service mode)
- ❑ Programmable boiler blow
- ❑ Automatic control turn-off after boiler extinction
- ❑ Blocking fan operation when stoking to the boiler
- ❑ Central heating circulation pump control
- ❑ "COMFORT SYSTEM"- a system that prevents the pump blockages when the boiler is not in operation
- ❑ Protection from boiler freezing and overheating
- ❑ Signalling when the boiler temperature sensor is damaged
- ❑ Modulated intensity of the display, it increases when the settings are being changed
- ❑ Compatible with Ekoster Control remote control system

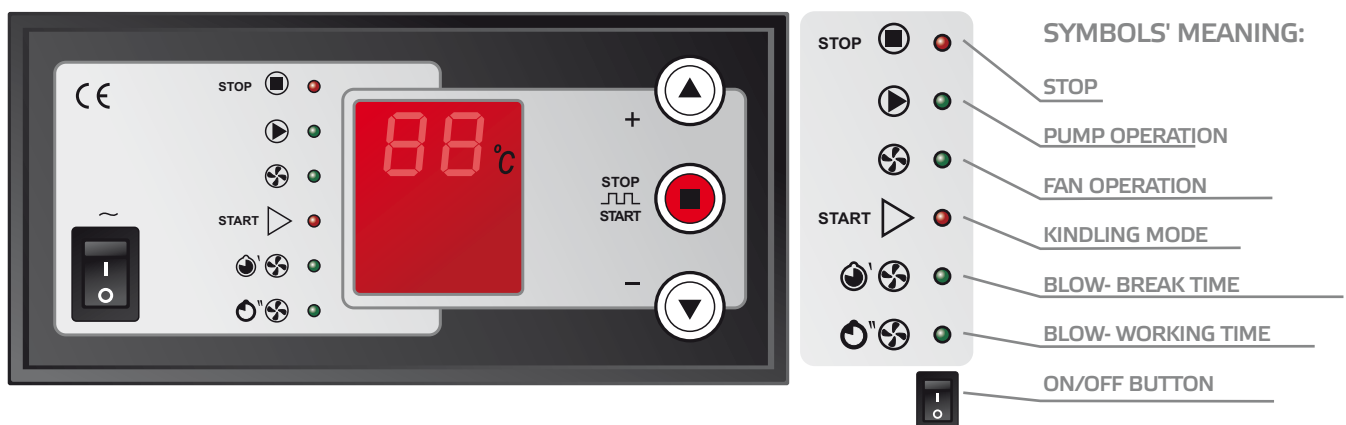

Ekoster Control control panel

The panel is designed to co-operate with EKOSTER microprocessor temperature regulator. EKOSTER Control enables the constant temperature reading of the central heating boiler, change of boiler temperature setting as well as activation and de-activation of control by regular communication with Ekoster regulator. The innovative built-in alarm system informs the user with a piercing sound if the threshold of 97°C has been overstepped, if the boiler temperature has dropped below 0°C, or if the sensor is damaged.

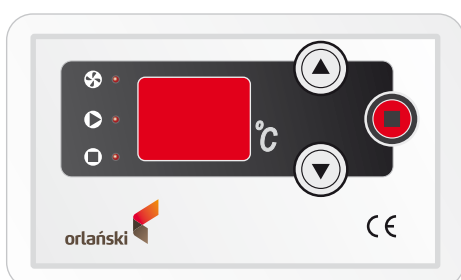

Technical data

Range of temperature displayed	-9°C - +99°C
Range of temperature setting	+60°C - +97°C

5-year warranty for boiler tightness

Installation diagram - ORLIGNO 200

Connecting ORLIGNO 200 boiler with a accumulation tank.

1. ORLIGNO 200 boiler
2. Thermo regulator
3. Accumulation tank
4. Electric heater
5. Three-way valve
6. Circulation pump
7. Room thermostat
8. Heating system exit
9. Safety group
10. Valve mixing hot water for domestic use
11. Pressure vessel

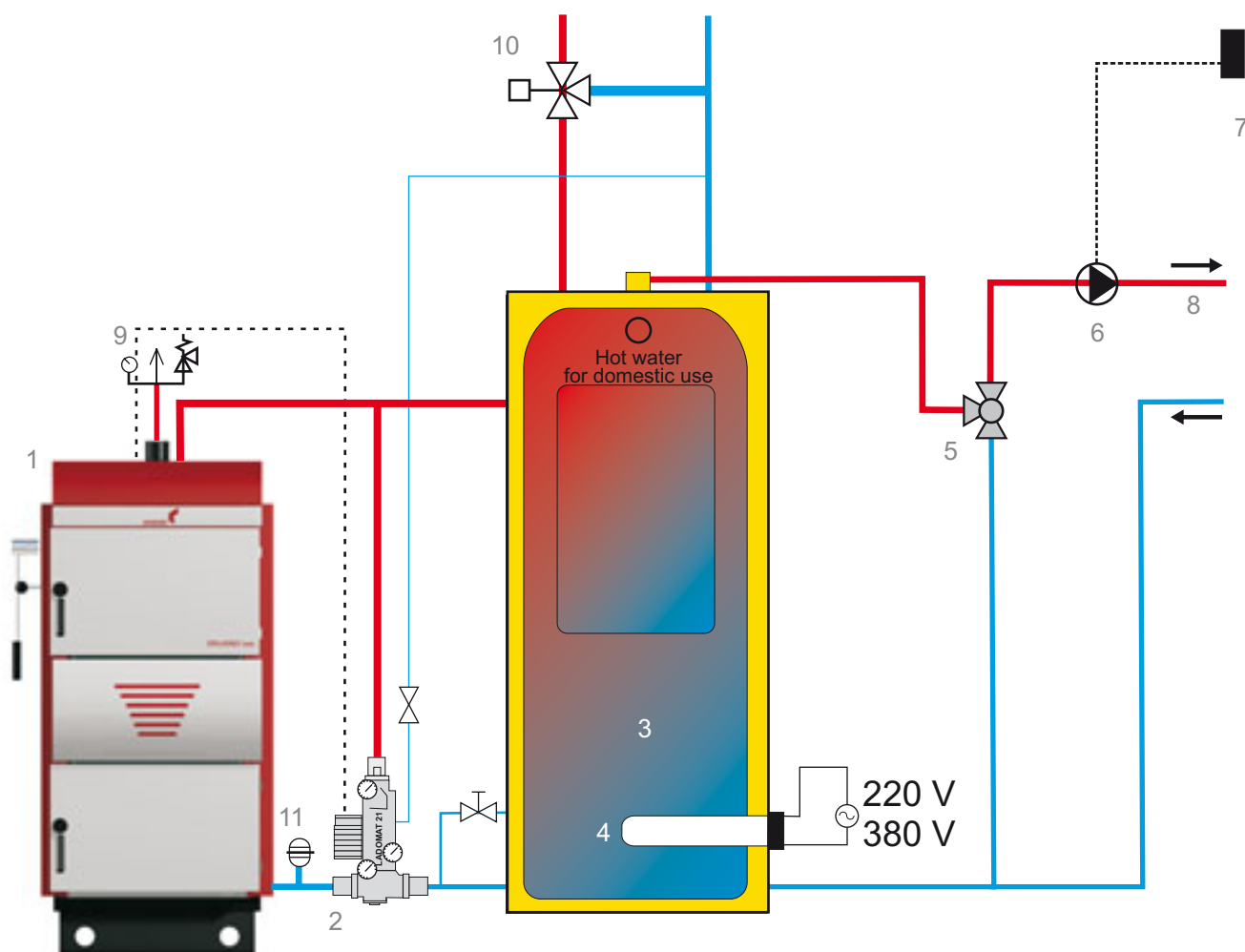

5-year warranty for boiler tightness

Installation diagram - ORLIGNO 200

Connecting ORLIGNO 200 boiler with a heat accumulation tank and a solar collector.

1. ORLIGNO 200 boiler
2. Thermo regulator
3. Accumulation tank
4. Electric heater
5. Three-way valve
6. Circulation pump
7. Room thermostat
8. Heating system exit
9. Safety group
10. Valve mixing hot water for domestic use
11. Coil
12. Solar collector
13. Solar pump
14. Pressure vessel

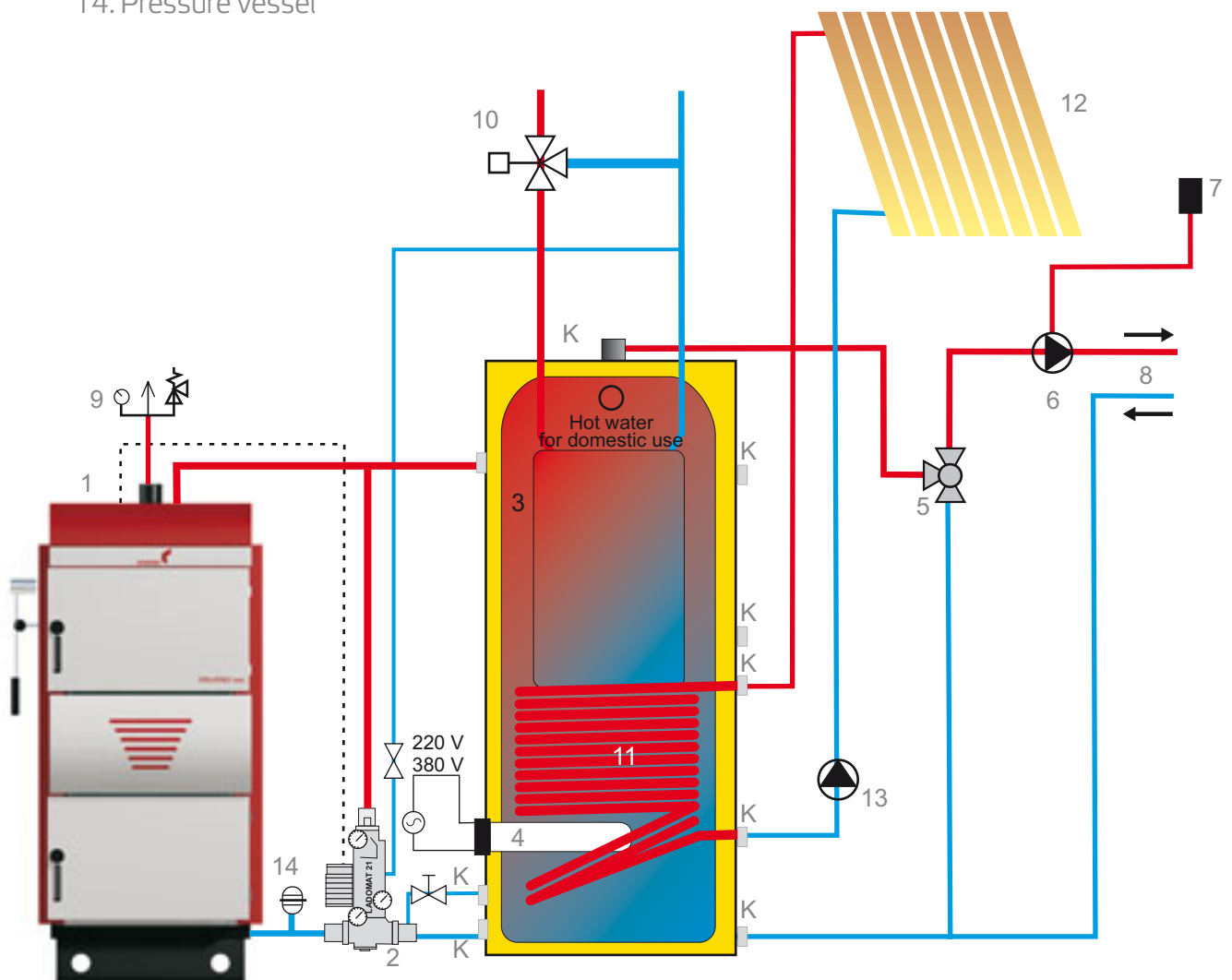

5-year warranty for boiler tightness

Installation diagram - ORLIGNO 200

Connecting ORLIGNO 200 boiler with a heat accumulation tank, solar collector and floor heating.

1. ORLIGNO 200 boiler
2. Thermo regulator
3. Container with hot water for domestic use feeder
4. Electric heater
5. Solar pump
6. Circulation pump
7. Ekoster Control
8. Central heating dispenser
9. Safety group
10. Three-way valve mixing hot water for domestic use
11. Coil
12. Solar collectors
13. Valve mixing floor heating feeder
14. Valve mixing floor heating feeder
15. Radiators
16. Floor heating
17. Pressure vessel

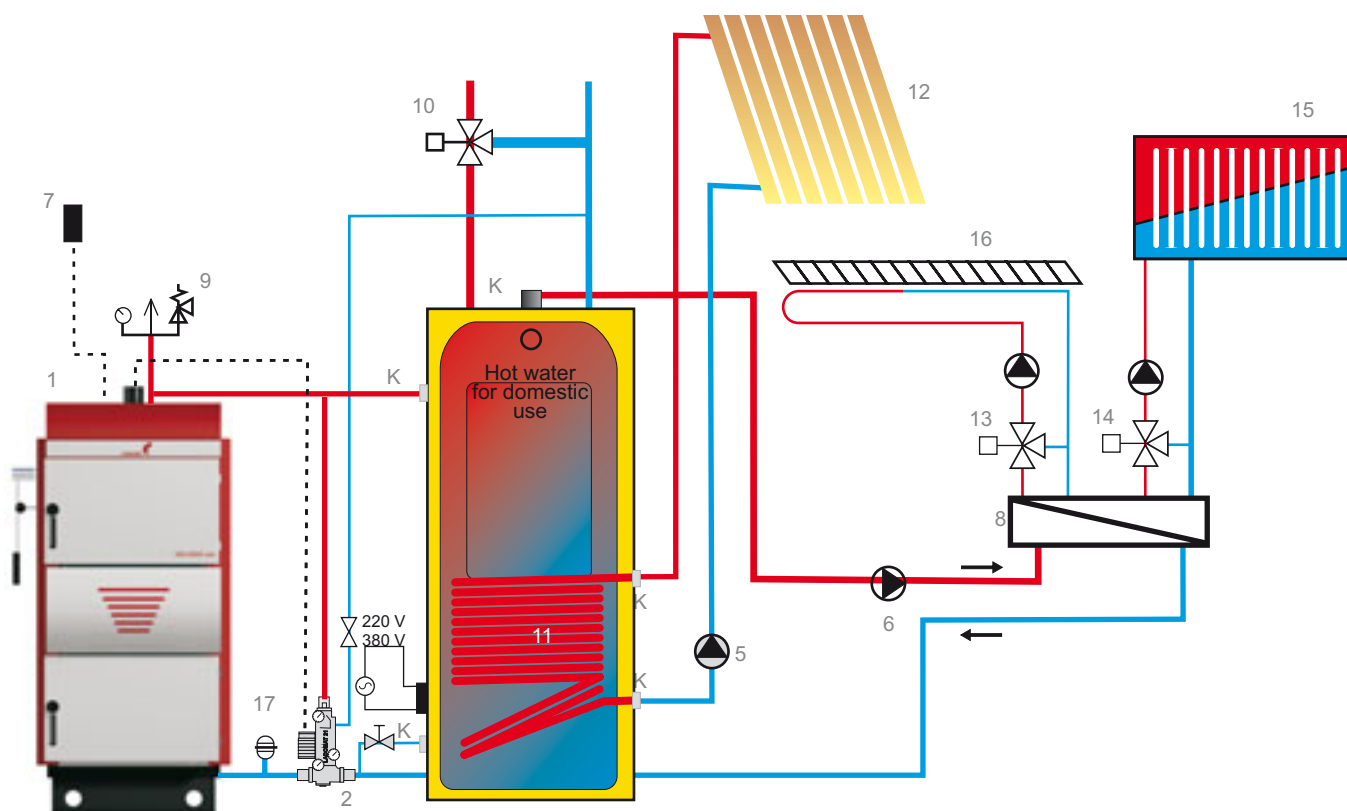

5-year warranty for boiler tightness

EKO-VIMAR ORLAŃSKI Sp. z o.o.
ul. Nyska 17b
48-385 Otmuchów, woj. opolskie, Polska

T +48 77 400 55 80-81, 400 55 91
F +48 77 439 05 03, 400 55 96
E biuro@ortanski.pl

www.ortanski.pl



Possible to obtain ecological grant

Distributor's data:

* ALL INFORMATION INCLUDED IN THE COMPANY'S ADVERTISEMENT IS FOR THE PURPOSE OF CONVEYING GENERAL INFORMATION ONLY AND CANNOT CONSTITUTE EVIDENCE IN LEGAL PROCEEDINGS.

** PRINTED ON 25.01.2011 R.